

System Specification

Brigade Model Number: **SS-443WA-KXHA**
 Brigade Stock Code: **#3166**

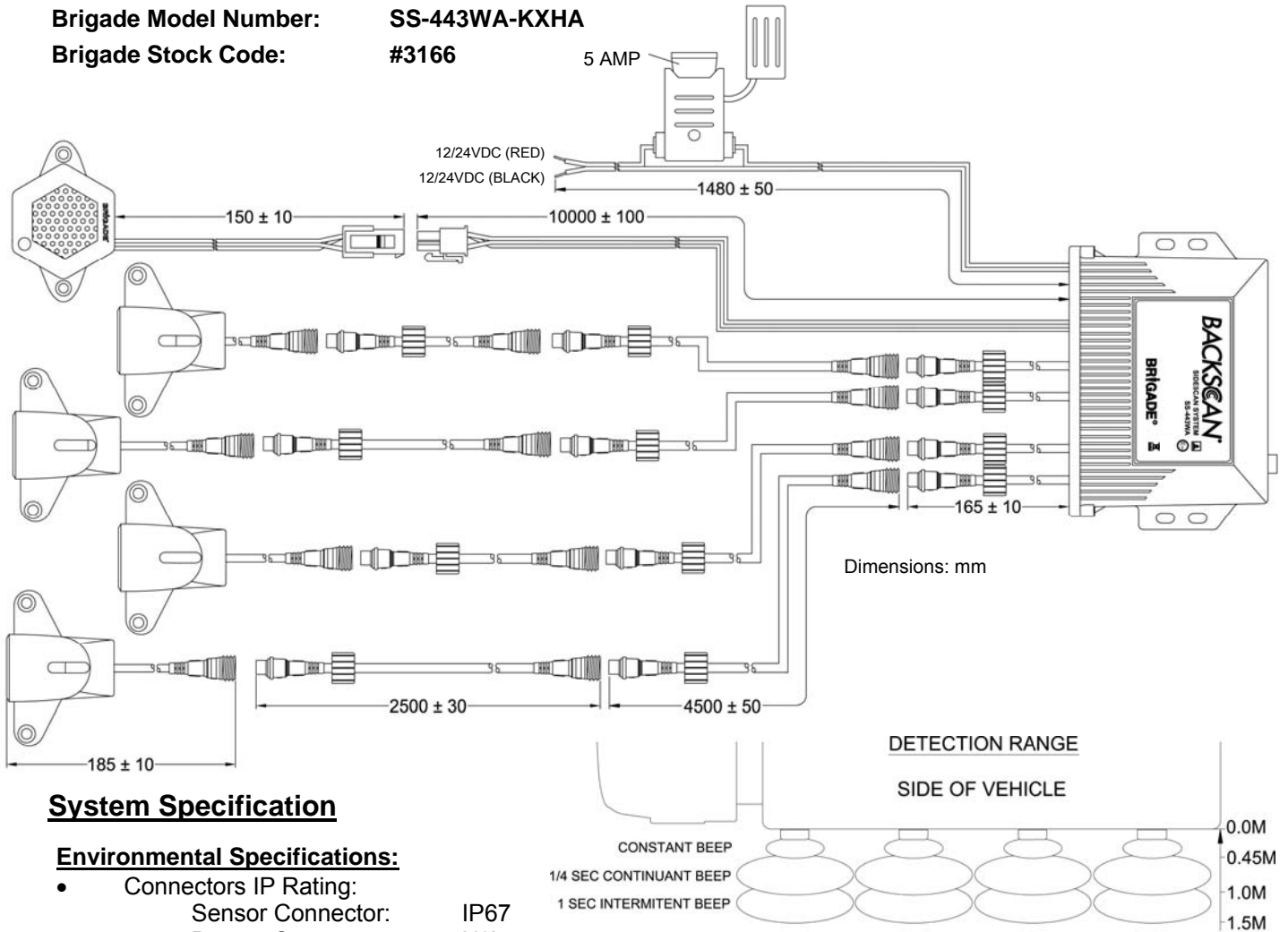

System Specification

Environmental Specifications:

- Connectors IP Rating: IP67
 Sensor Connector: IP67
 Buzzer Connector: N/A
- Operating Temperature: Sensors & Control Unit: -30° to +80°C
- Storage Temperature: TBC

Approved Standards:

- E (Regulation 10)

Technical Specifications:

- Operating Voltage: 12/24 Vdc
- Current Consumption: ≤250mA @ 12 Vdc
- Power Consumption: Max 3 Watts @ 12 Vdc
- Sensor Type: KXHA
- Sensor Frequency: 40 KHz
- Signal Type: Simulated Signal
- Minimum Mounting Height: 500 mm
- Detection Zone Tolerance: +/- 5cm
- Buzzer Type: Piezo
- Buzzer Volume: 90 - 105 dB(A)

Technical Specifications Continued...

- Cable Thickness: Power Cables: 22 AWG
- Weight: 1150 +/- 100 Grams
- Control Unit Dimensions: 132 mm (W) x 24 mm (D) x 92mm (H)
- Sensor Centre Mounting Holes: 52mm
- Buzzer Centre Mounting Holes: 60mm
- Control Unit Mounting Holes: 122mm
- Control Unit Material: ABS
- Colour: Black
- LED Colour in Buzzer: Red

Features:

- Self Diagnostic Function.
- Interchangeable Sensors.
- Low current consumption.
- LED Indicator in Buzzer to show system is active and ready.
- High Sensitivity Sensors.
- Sealed Fuse Holder.